



Epson Stylus[®] Pro WT7900

QUICK REFERENCE GUIDE

Printer Parts

Front

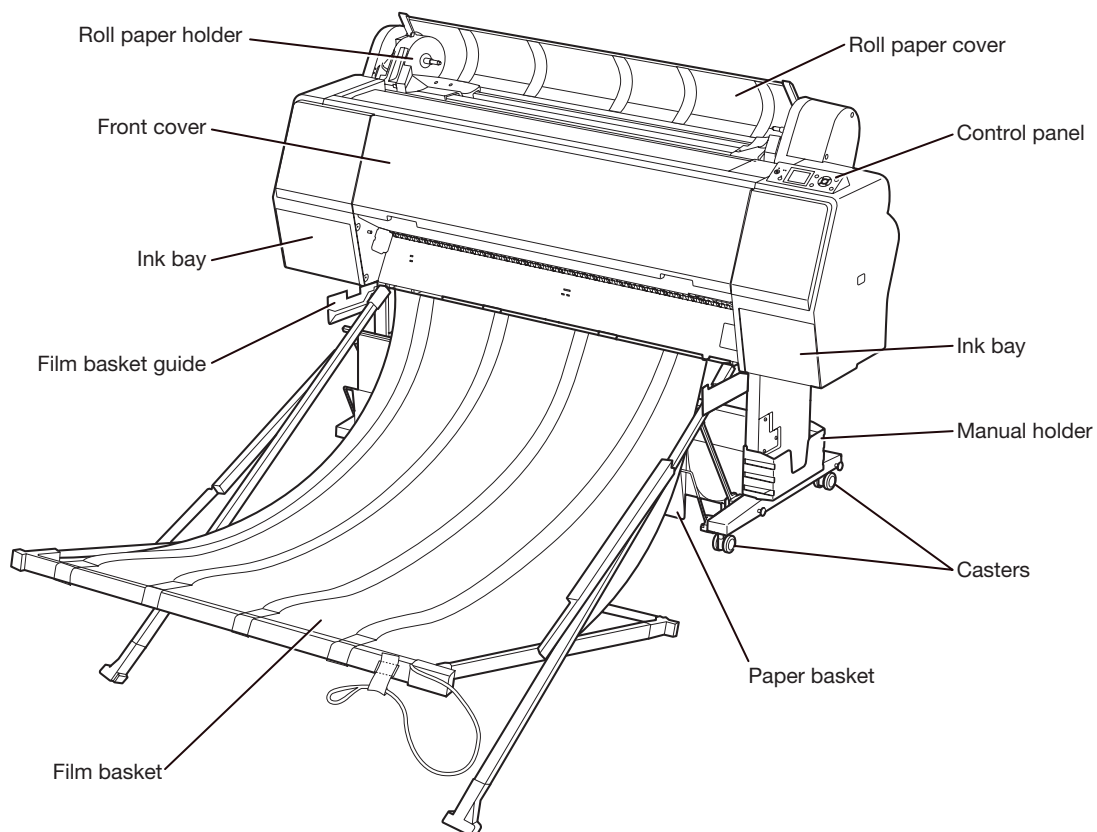

Back

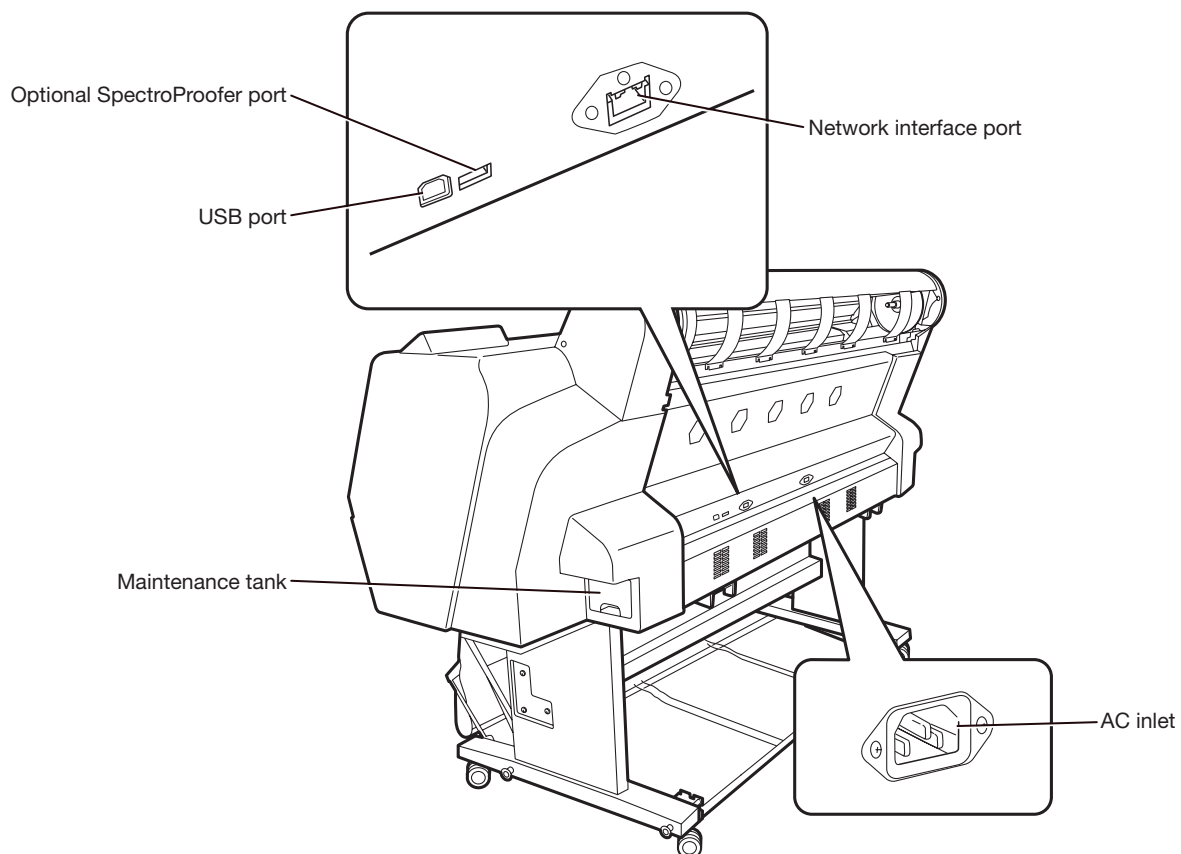

Loading Epson Media

- 1 Open the roll paper cover.
- 2 Push the lock lever down firmly, then move the roll paper holder to the left.

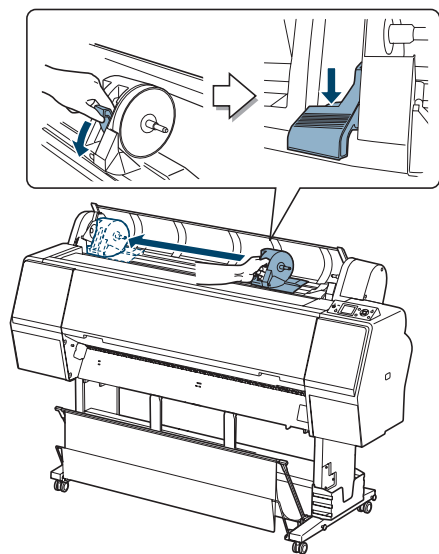

- 3 Set the roll paper on top of the printer.

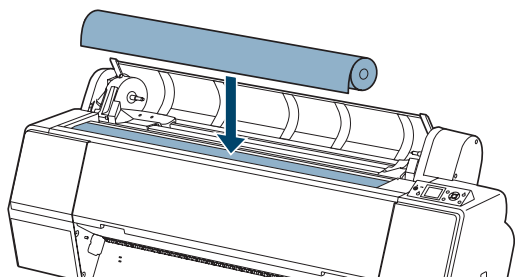

- 4 If necessary, adjust the roll paper adapters to fit the core size of the roll paper. Then release the tension lever on each adapter.

2-inch core

3-inch core

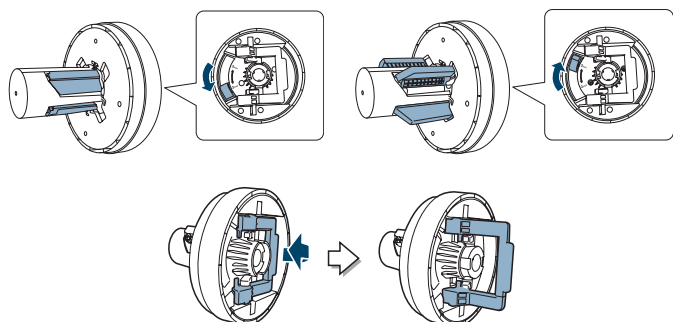

- 5 Push the adapters into the paper core at both ends of the roll. Then press down on the tension levers to secure the adapters on the roll.

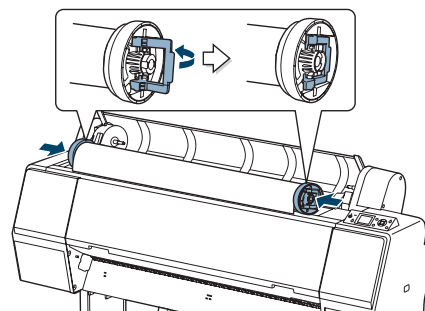

- 6 Move the roll paper all the way to the right.

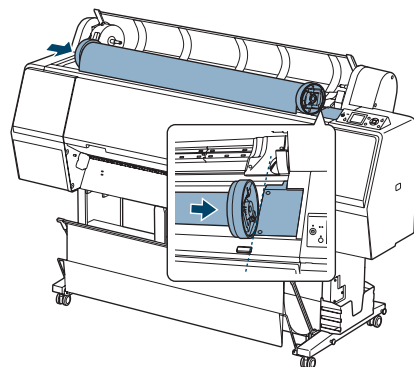

- 7 Slide the roll paper holder to align the ▲ arrow with the roll paper adapter.

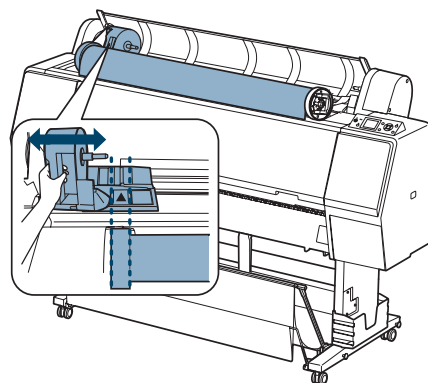

- 8 Roll the paper slowly into position.

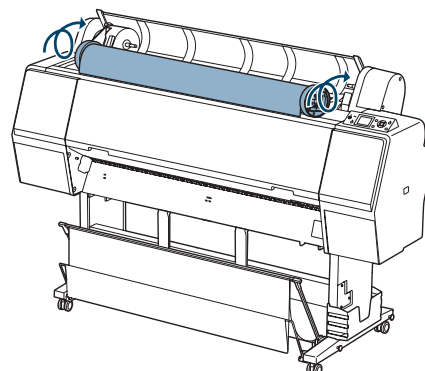



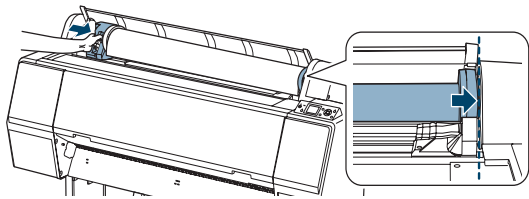

Loading Epson Media (continued)

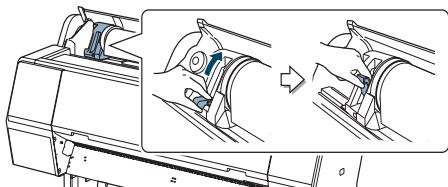

- 9** Grasp the left roll paper holder and slide it to the right as far as it will go. Make sure the roll paper is pushed all the way to the right.



- 10** Pull up the lock lever to lock the paper in place.



- 11** Press the ◀ paper source button until  or  appears on the display. Choose  to cut the paper automatically after each page is printed, or  to decide for yourself when to cut the paper.

- 12** If the  light is not on, press the  button to load paper.

- 13** Insert the paper all the way into the slot.

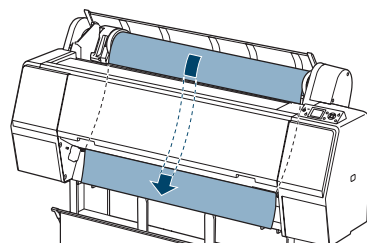



If the paper doesn't come out, lower the suction by pressing the ▼ button. Return the suction to normal after the paper is loaded.

- 14** Close the roll paper cover.

- 15** Press the  button to secure the paper. Wait for the paper to move into position.

- 16** Select the paper type setting (such as ClearProof Film) to match the type of paper you've loaded.

Removing Epson Media

- 1** Open the roll paper cover.
- 2** Press the  button to release the paper. The paper rewinds automatically.
- 3** If you don't plan to reload paper immediately, press the  button again to exit paper loading mode.
- 4** Push down the lock lever firmly to release it. Then grasp the roll paper holder and slide it all the way to the left to release the roll.

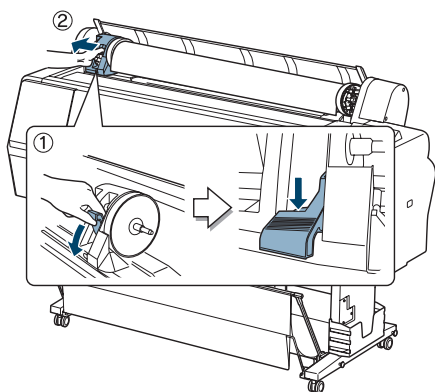

- 5** Roll the paper forward so it rests on top of the printer.

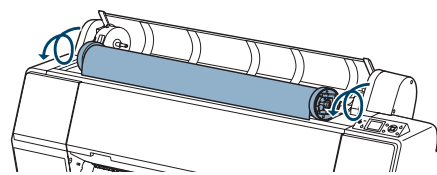

- 6** Pull up the tension levers, then remove the adapters from the paper roll.

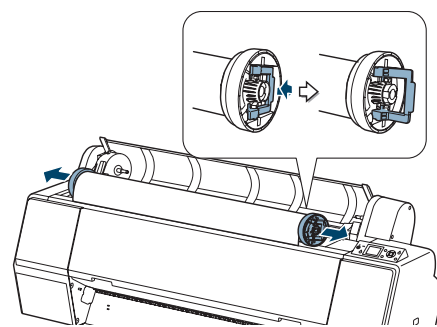

- 7** Place the roll in its original package.

Shaking the White Ink Cartridge

To maintain optimal image quality, remove the white ink cartridge and shake it once a week. The printer will tell you when this is required:

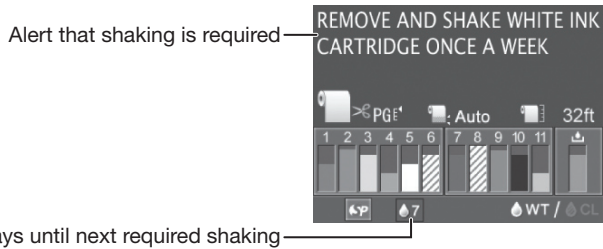

- 1 Press the button to unlock the ink bay. Press to select OPEN LEFT COVER, then press OK.
- 2 Open the cover and remove the white ink cartridge.

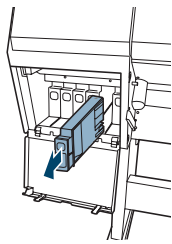

- 3 Hold the cartridge horizontally and shake it for about 30 seconds (about 100 times). Shake it back and forth about an inch or two (5cm) in each direction.

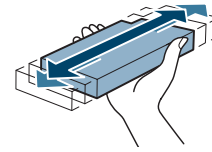

WARNING: If ink gets on your hands, wash them thoroughly with soap and water. If ink gets in your eyes, flush them immediately with water.

- 4 Hold the cartridge with the arrow mark pointing toward the printer. Then insert the cartridge into the slot.

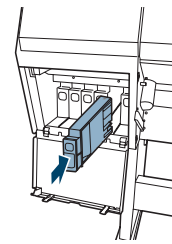

- 5 Close the ink cover.

Checking and Cleaning the Print Head

Checking the Nozzles

The printer automatically checks the nozzles and cleans them if necessary, but you can also check them yourself.

- 1 Make sure roll paper or letter- or A4-size cut sheet paper is loaded in the printer. If you need to check the white ink nozzles, use film to ensure that the ink is visible.
- 2 Press Menu.
- 3 Press until TEST PRINT is selected, then press .
- 4 Make sure NOZZLE CHECK is selected, then press .
- 5 Select one of the following, then press .
 - PRINT WITH WHITE INK to check all nozzles including white ink. If the printer is in cleaning liquid mode, white ink will be loaded first.
 - PRINT NOW to check nozzles without switching ink. If the printer is in cleaning liquid mode, no white ink will be used.

- 6 Press OK to start printing the nozzle check pattern.
- 7 After the pattern is printed, use at least a 10× eye loupe to examine it.

- If the pattern looks good, the print head is clean. The text “CL : OK” means the cleaning nozzles are working properly.

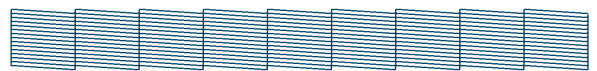

CL : OK

- If any segments are missing, or if the cleaning nozzle status is shown as “NG” (no good), run a cleaning cycle as described in the next section.



CL : NG

Checking and Cleaning the Print Head (continued)

Cleaning the Nozzles

- 1 Press the **A▶A** cleaning button on the control panel.
- 2 Press **▲** or **▼** to select one of the following:
 - **NORMAL CLEANING**—Press **OK** to start the cleaning cycle.
 - **CLEAN COLOR PAIRS**—Press **OK**, select the color pair you want to clean, then press **OK** to start the cleaning cycle. Use if you know which color(s) you need to clean; this saves ink from being used unnecessarily to clean working nozzles.
 - **POWER CLEANING**—Press **OK** to start the cleaning cycle. Use only if three cycles of normal cleaning doesn't clear the nozzles.

- 3 When cleaning is finished and the **⏻** Power light stops flashing, print the nozzle check again to confirm that the head is clean.

You can also turn the printer off and leave it overnight to dissolve any dried ink, then clean the print head again the following morning with a normal cleaning cycle.

If you continue to detect a problem with the white ink nozzles, perform a white ink refresh as described in the *User's Guide*.

Aligning the Print Head

If your prints look grainy or blurry, or you see misregistration or “ghosting,” you need to align the print head.

- 1 Load the bundled roll paper included with the printer. You can also use Epson film or other compatible Epson media. For best results, use the same width of paper that you plan to print with.
- 2 Press **▶** Menu.
- 3 Press **▲** or **▼** until **HEAD ALIGNMENT** is selected, then press **▶**.
- 4 Make sure **PAPER THICKNESS** is highlighted, then press **▶**.
- 5 Make sure **SELECT PAPER TYPE** is highlighted, then press **▶**. Select the paper type loaded in the printer and press **OK**. (Select **Bundle Roll Paper** if you've loaded the bundled paper included with the printer.)
- 6 Press **◀** twice to return to the Head Alignment menu.

- 7 Press **▼** to select **ALIGNMENT**, then press **▶**.

- 8 Make sure **AUTO** is highlighted, then press **▶**.

- 9 Make sure **UNI-D** (uni-directional) is highlighted, then press **▶**. This is the type of alignment to start with.

- 10 Press **OK** to start the alignment process.

Each alignment takes about 7 minutes. The printer scans the alignment pattern and adjusts itself automatically. Don't open the front cover or turn off the printer during this process.

- 11 When the uni-directional alignment is finished, press **▶** Menu.

- 12 Select **HEAD ALIGNMENT**, select **ALIGNMENT**, and then select **AUTO**.

- 13 Select **BI-D** and press **OK** to start the alignment process.

Checking Ink Levels and Replacing Ink Cartridges

Before you begin a large print job, you should check your ink levels. If one of your cartridges is low, you can replace it before you start. Or you can wait until the ink runs out, replace the cartridge, and then continue the job.

Checking Ink and Maintenance Tank Levels

The easiest way to check ink levels is from the control panel. The numbers above the ink cartridge icons correspond to the 11 cartridge slots in the printer.

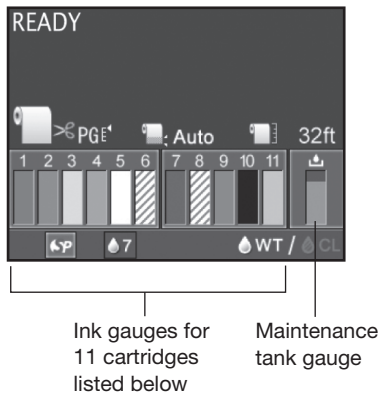

Replacing Ink Cartridges

When one of the ink icons flashes, and **INK LOW** is displayed on the LCD, the cartridge is nearly expended. Check the LCD to see which cartridge is low, and make sure you have the correct replacement cartridge.

Epson UltraChrome® HDR ink cartridges

Ink bay	Slot no.	Cartridge	150 ml	350 ml	700 ml
Left	1	Cyan (C)	T642200	T596200	T636200
	2	Orange (O)	T642A00	T596A00	T636A00
	3	Yellow (Y)	T642400	T596400	T636400
	4	Light Cyan (LC)	T642500	T596500	T636500
	5	White (WT)	T642C00	T596C00	—
	6	Cleaning Liquid (CL)	T642000	—	—
Right	7	Vivid Magenta (VM)	T642300	T596300	T636300
	8	Cleaning Liquid (CL)	T642000	—	—
	9	Green (G)	T642B00	T596B00	T636B00
	10	Photo Black (PK)	T642100	T596100	T636100
	11	Vivid Light Magenta (VLM)	T642600	T596600	T636600

When one of the icons has an **X** and **REPLACE INK CARTRIDGE** is displayed, the cartridge is expended. To replace the cartridge, first make sure the printer is on.

- 1 Press the button to release the ink cover. If necessary, select the ink bay for the cartridge you want to replace, then press **OK**.
- 2 Open the ink cover all the way.

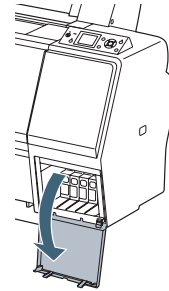

- 3 Push in the low or expended cartridge to release it.

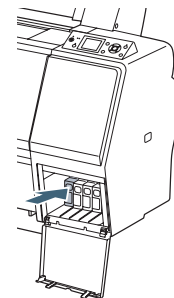

- 4 Remove the expended ink cartridge from the printer.

Warning: Do not shake the expended cartridge, or ink may leak. If ink gets on your hands, wash them thoroughly with soap and water. If ink gets in your eyes, flush them immediately with water.

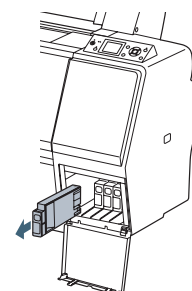

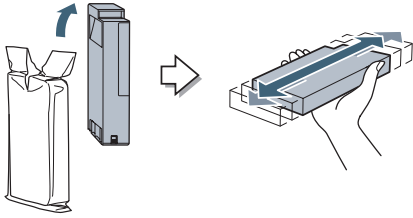

Checking Ink Levels and Replacing Ink Cartridges (continued)

- 5** Make sure the replacement cartridge is the correct color, and remove it from its package. Gently shake the cartridge before installing it: 30 seconds for the white ink cartridge, or 5 seconds for all others.

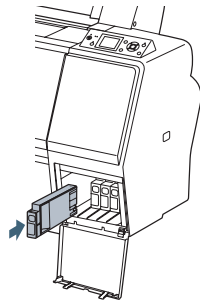

- 6** Hold the cartridge with the arrow mark pointing toward the printer. Then insert the cartridge into the slot. Don't force it.



Note: If you can't insert the cartridge smoothly, you may have the wrong cartridge. Check the package and product code. If the  Ink light remains on after installing the cartridge, try removing and then reinserting it.



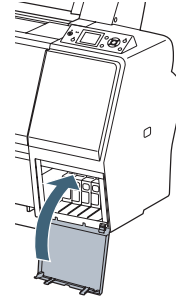

- 7** Close the ink cover.



Replacing Printer Parts

Replacing the Paper Cutter

If you notice that the paper isn't cut cleanly, you may need to replace the cutter (part # C12C815331).

- 1** Press the  Menu button on the printer, then press  until MAINTENANCE is highlighted.
- 2** Press  again. Press  to highlight CUTTER REPLACEMENT.
- 3** Press  to display EXECUTE, then press OK. The paper cutter moves to the replacement position.
- 4** Turn off the printer.

- 5** To remove the cutter cover, press in the tab and pull down the cover.

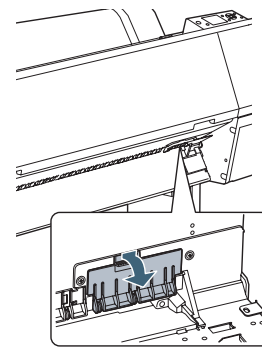

- 6** Loosen the screw using a Phillips-head screwdriver.

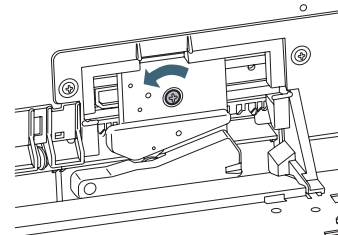

Replacing Printer Parts (continued)

- 7** Carefully remove the cutter.

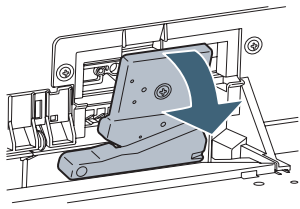

- 8** Insert the new cutter. Make sure the cutter pin goes into the hole.

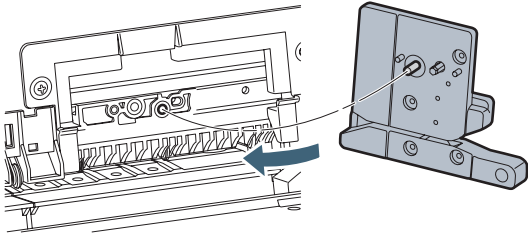

- 9** Tighten the screw.

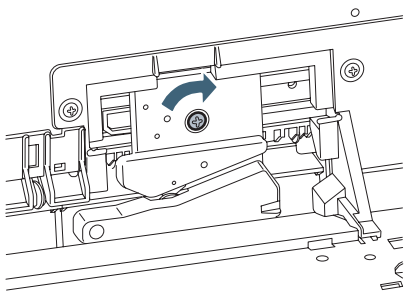

- 10** Insert the cutter cover, then press it in until it snaps into place.

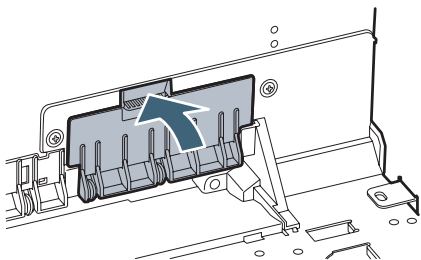

- 11** Turn the printer back on.

- 12** Run the cutter adjustment from the Maintenance menu using the control panel.

Replacing the Maintenance Tank

You need to replace the maintenance tank (part # C12C890191) when you see **MAINTENANCE TANK FULL** on the LCD, the icon has an **X**, and the printer won't print.

- 1** Turn off the printer.
- 2** Pull out the maintenance tank as shown.

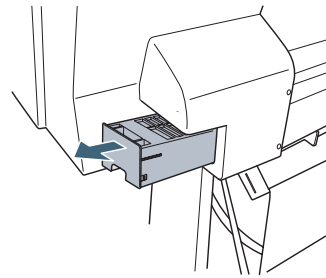

Caution: Do not tip the tank or ink may spill out.

- 3** Place the used tank in the plastic bag included with the new tank and dispose of it carefully.

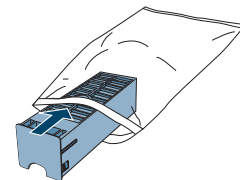

- 4** Insert the new tank.

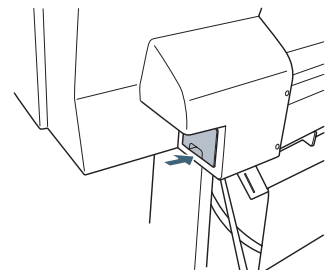

Control Panel Menus

Boldface type indicates the default setting. Press the ► **Menu** button to access the menus. See the *User's Guide* for details.

Menu	Item	Settings / Explanation
PRINTER SETUP	PLATEN GAP	STANDARD , NARROW, WIDE, WIDER, WIDEST
	PAGE LINE	ON , OFF
	ROLL PAPER MARGIN	15mm , 3mm
	PAPER SIZE CHECK	ON , OFF
	PAPER SKEW CHECK	ON , OFF
	REFRESH MARGIN	ON , OFF
	AUTO NOZZLE CHECK	ON: PERIODICALLY , ON: EVERY JOB, OFF
	PRINT NOZZLE PATTERN	OFF , ON: EVERY PAGE, ON: EVERY 10 PAGES
	AUTO WT INK REFRESH	ON , OFF
	INITIALIZE SETTINGS	Restores default settings

TEST PRINT	NOZZLE CHECK	Shows clogged or deflected nozzles
	STATUS SHEET	Printer settings, total prints, and maintenance tank capacity remaining
	NETWORK STATUS SHEET	Network settings
	JOB INFORMATION	Date and Time and Ink and paper used for the last 10 jobs; most recent job is number 0
	CUSTOM PAPER	Information about registered paper configurations

MAINTENANCE	CHANGE INK	Depending on the white ink status, replaces it with cleaning fluid (WT > CL) or vice-versa (CL > WT)
	CUTTER ADJUSTMENT	Adjusts cutter position
	CUTTER REPLACEMENT	Moves the cutter to the replacement position
	CLEANING	NORMAL CLEANING , CLEAN COLOR PAIRS, POWER CLEANING
	CLOCK SETTING	MM/DD/YY HH:MM

PRINTER STATUS	VERSION	Current firmware version
	INK LEVEL	Percentage of ink remaining in each cartridge
	MAINTENANCE TANK	Percentage of capacity remaining in the maintenance tank
	JOB HISTORY	Ink in milliliters and paper in square centimeters for each saved job; most recent job is number 0
	TOTAL PRINTS	Number of pages printed
	EDM STATUS	Status of the printer on myEpsonPrinter.com. If the printer is registered and enabled, displays time of last status upload.

Control Panel Menus (continued)

PAPER SETUP	ROLL PAPER REMAINING	Setting appears only when no paper is loaded
	REMAINING PPR SETUP	OFF , ON
	ROLL PAPER LENGTH	From 15 to 300 ft
	ROLL LENGTH ALERT	From 4 to 50 ft
	PAPER TYPE	Media type loaded in the printer
	CUSTOM PAPER	Paper No 1 to 10
	PAPER TYPE	Media type loaded in the printer
	PLATEN GAP	STANDARD , NARROW, WIDE, WIDER
	THICKNESS PATTERN	PRINT
	PAPER FEED ADJUST	-0.70% to 0.70%
	DRYING TIME	0.0 sec. to 10.0 sec.
	PAPER SUCTION	STANDARD , -1, -2, -3, -4
	SET ROLL PAPER TENSION	STANDARD , HIGH, HIGHER
	REMOVE SKEW	ON , OFF
HEAD ALIGNMENT	PAPER THICKNESS	
	SELECT PAPER TYPE	Media type loaded in the printer.
	SELECT THICKNESS	8 mil (0.2 mm) , 4 mil to 60 mil (0.1 to 1.5 mm)
	ALIGNMENT	
	AUTO	UNI-D, BI-D, BI-D #1, BI-D #2, BI-D #3

NETWORK SETUP	NETWORK SETUP	DISABLE , ENABLE
	IP ADDRESS SETTING	AUTO , PANEL
	IP, SM, DG SETTING	IP address, subnet mask, default gateway
	BONJOUR	ON , OFF
	INIT NETWORK SETTING	Resets all network settings
OPTIONS SETUP	Spectro Proofer	Displays status of various parts and performs device alignment

Where To Get Help

Epson PreferredSM Unit ID number

Date of purchase

Serial number

Service	Access
Telephone support	Call (888) 377-6611. Make sure you have your Unit ID number. If you experience any difficulty with the toll-free number or your Unit ID number, call (562) 276-1305.
Internet	Go to epson.com/support to download drivers and firmware, access product documentation and troubleshooting, and get technical advice through e-mail.
Support for non-Epson RIP	Contact the RIP manufacturer.
Web-based printer information management system	myEpsonPrinter.com

Control Panel Lights and Buttons

